

VIBRATOR MOTORS

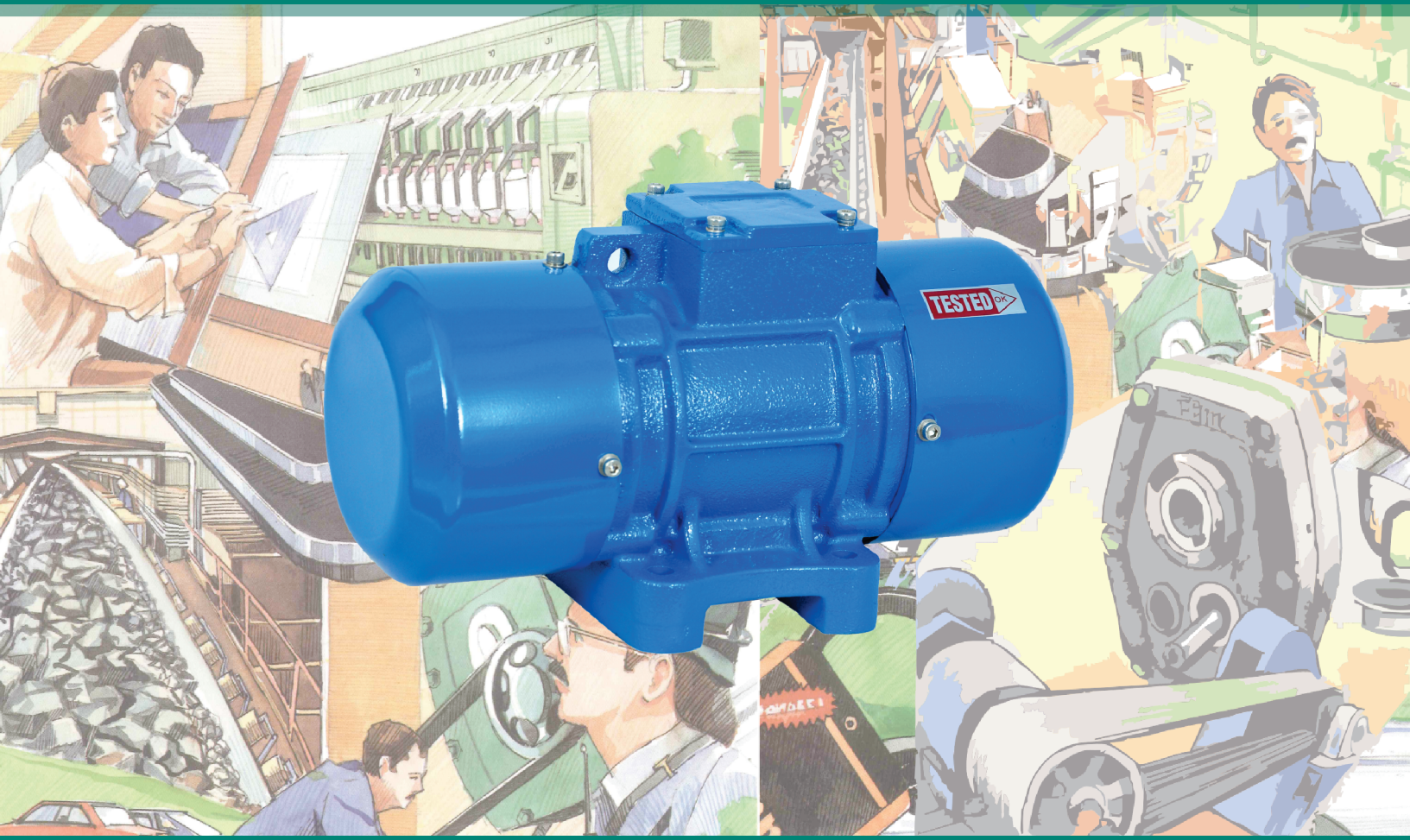

POWER TRAN[®]

VIBRATOR MOTOR

Vibrator Motor is the machine which generates powerful centrifugal force vibration by rotation of eccentric weights attached in the rotor axis both ends. The value of these centrifugal forces can be changed by adjustment of the eccentric weights while the motors are at standstill condition. When used as a single unit, they impact circular vibrations. If linear vibrations are needed, two vibrators running in the opposite direction should be used.



FEATURES

- Rugged construction for tough environment.
- Motor winding is vacuum impregnated.
- Totally dust proof air cooled design can operate in dusty environments. Complies with IP55 specification.
- F-Class winding: Impervious to dust, moisture and vibrations.
- Terminal box connector sealed with layer of resin to prevent damage due to vibrations.
- Vibrations force is adjustable from zero to maximum by adjusting position of unbalance weights provided on both sides of the motor shaft.
- Drive shaft made from sized alloy steel to withstand stress at high speeds.
- Body made from high grade C.I. casting.
- Maintenance free sealed imported pre-lubricated heavy ball bearings.
- Amplitude of vibration can be controlled. Noise free performance.
- Thermal overload protection: Thermistor 140°C or other temperatures are available for all vibrator motors on request.
- Permanent and well legible setting marking of the unbalance weights.
- Multiple eye bolts for higher range vibrators

APPLICATION

- Vibrating table
- Vibrating Grizzly Feeders
- Hoppers
- Silos
- Seed cleaners
- Vibrating conveyors

- Vibrating separators & Vibrating screens
- Vibratory compaction & Test table
- Bin activators, bin discharging
- Vibrating feeders
- Knock-out grates

INSTALLATION GUIDELINES

- Requirements of the place of installation
Vibrator motor should be installed on flat surface; else local forces may develop breakage of legs.
- Use quality bolts and quality self-locking nuts. Tighten only with a torque wrench.
- Retighten bolts after 15 minutes of operation time. Check bolts and nuts frequently until retightening is no longer possible.
- Vibrating force on both ends of the motor shaft should be adjusted equally otherwise the operation will be erratic.

Vibration-stiff

Caution: If unsuitable screws and nuts are used or the screws and nuts not properly tightened, the vibrator motor may become loose and cause serious damage. Please note the most of the failures and faults are caused by incorrect or loose screwed connection.



FIXING

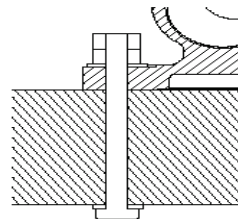

Smooth through borehole
+ Screw
+ Flat Washer
+ Nut and counter nut

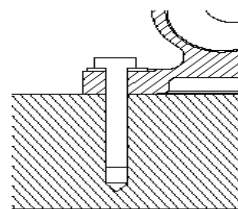

Tapped threaded borehole
+ Screw
+ Flat Washer



PERFORMANCE DATA OF THE THREE PHASE & SINGLE PHASE VIBRATOR

VIBRATOR MOTOR PERFORMANCE CHART										
MODEL 415V	MODEL 230V	SPEED IN RPM	POWER IN KW	HP	WORKING MOMENT (KgcM)	CENTRIFUGAL FORCE (N)	CURRENT IN AMPS		MOTOR WEIGHT(Kg)	
							415V	230V	415V	230V
FVM 18/30		3000	0.18	0.25	4.1	1886	0.4	-	11	-
FVM 35/30			0.18	0.25	7.7	3514	0.4	-	12	-
FVM 40/30	FVM S40/30	RPM	0.37	0.5	8.6	3924	1	3.6	17.6	17.1
FVM 42/30			0.37	0.5	9.3	4252	1	-	18.4	-
FVM 76/30	FVM S76/30	RPM	0.75	1	16.8	7638	2	6	25	26.8
FVM 112/30	FVM S112/30		1.5	2	24.8	11282	3.2	11.2	40.3	42
FVM 255/30		RPM	2.2	3	56	25482	4.5	-	51.6	-
FVM 382/30			3.7	5	80	38259	7.5	-	54	-
FVM 18/15		1500	0.18	0.25	16.2	1849	0.6	-	14	-
FVM 28/15			0.18	0.25	24.4	2774	0.6	-	14.5	-
FVM 42/15	FVM S42/15	RPM	0.37	0.5	37.2	4230	1.1	3.9	23	23.5
FVM 56/15			0.37	0.5	49.6	5641	1.1	-	23.4	-
FVM 96/15	FVM S96/15	RPM	0.75	1	84.1	9555	2.2	6.8	37	36.5
FVM 130/15			0.75	1	114.9	13052	2.2	-	38	-
FVM 276/15		RPM	1.1	1.5	243	27623	2	-	72	-
FVM 191/15	FVM S191/15		1.5	2	168	19119	3.3	12	61	60
FVM 321/15		RPM	1.5	2	282	32181	3.4	-	75	-
FVM 220/15			2.2	3	194	22098	4.6	-	-	-
FVM 380/15		RPM	2.2	3	334	37982	4.9	-	-	-
FVM 540/15			3.7	5	474	53865	7.9	-	-	-
FVM 50/10		1000	0.37	0.5	100	5040	1.4	-	-	-
FVM 116/10			0.75	1	231	11663	2.3	-	55	-
FVM 143/10		RPM	0.75	1	283	14302	2.3	-	56	-
FVM 180/10			0.75	1	357	18016	2.4	-	61	-
FVM 240/10		RPM	1.5	2	476	24032	4	-	-	-
FVM 306/10			2.2	3	608	30693	5.5	-	-	-

VIBRATOR MOTOR DIMENSIONAL CHART

DIMENSIONAL SPECIFICATION

MODEL 415V	MODEL 230V	SPEED IN RPM	POWER IN KW	HP	DRAWING	C	M	A	B	G	HOLE	D	E	F	H	L	N	
FVM 18/30		3000 RPM	0.18	0.25	A	270	60	90	100	10	4	131	150	18	63	120	118	
FVM 35/30			0.18	0.25	A	270	60	90	100	10	4	131	150	18	63	120	118	
FVM 40/30	FVMS40/30		0.37	0.5	A	325	90	90	120	12	4	155	180	32	71	120	140	
FVM 42/30			0.37	0.5	A	325	90	90	120	12	4	155	180	32	71	120	140	
FVM 76/30	FVMS76/30		0.75	1	A	352	100	100	105	160	13	4	215	200	32	80	152	157
FVM 112/30	FVMS112/30		1.5	2	A	392	100	100	120	200	17	4	250	230	46	92	192	178
FVM 255/30			2.2	3	A	410	130	130	120	200	17	4	250	250	46	100	192	208
FVM 382/30			3.7	5	B	630	140	140	155	255	26	4	332	345	41	180	350	310
FVM 18/15			1500 RPM	0.18	0.25	A	280	80	90	120	13	4	155	200	32	71	120	157
FVM 28/15				0.18	0.25	A	280	80	90	120	13	4	155	200	32	71	120	157
FVM 42/15	FVMS42/15	0.37		0.5	A	422	140	140	105	160	13	4	215	230	32	80	152	178
FVM 56/15		0.37		0.5	A	422	140	140	105	160	13	4	215	230	32	80	152	178
FVM 96/15	FVMS96/15	0.75		1	A	512	160	160	120	200	17	4	250	250	46	92	192	208
FVM 130/15		0.75		1	A	512	160	160	120	200	17	4	250	250	46	92	192	208
FVM 276/15		1.1		1.5	B	477	120	120	120	190	17	4	250	230	46	130	236	208
FVM 191/15	FVMS191/15	1.5		2	A	612	210	210	120	200	17	4	250	250	46	92	192	208
FVM 321/15		1.5		2	B	477	120	120	120	190	17	4	250	230	46	130	236	208
FVM 220/15		2.2		3	B	477	120	120	120	190	17	4	250	230	46	130	236	208
FVM 380/15		2.2	3	B	588	140	140	155	255	23.5	4	302	298	36	147	308	264	
FVM 540/15		3.7	5	B	630	140	140	180	280	26	4	332	345	41	180	350	310	
FVM 50/10		1000 RPM	0.37	0.5	A	512	160	105	160	13	4	215	200	32	80	152	178	
FVM 116/10			0.75	1	B	477	120	120	120	190	17	4	250	230	46	130	236	208
FVM 143/10			0.75	1	B	477	120	120	120	190	17	4	250	230	46	130	236	208
FVM 180/10			0.75	1	B	477	120	120	120	190	17	4	250	230	46	130	236	208
FVM 240/10			1.5	2	B	588	140	140	155	255	23.5	4	302	298	36	147	308	264
FVM 306/10			2.2	3	B	630	140	140	155	255	26	4	332	345	41	180	350	310

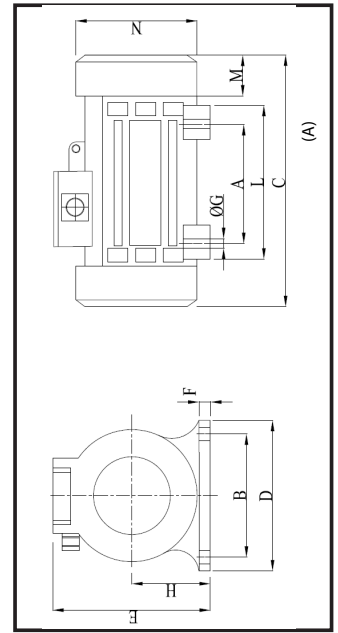
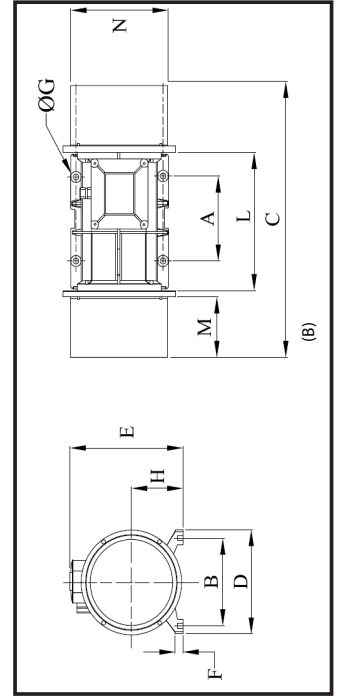

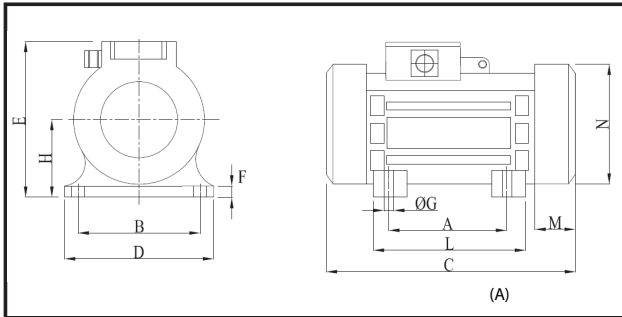

DRAWING - A

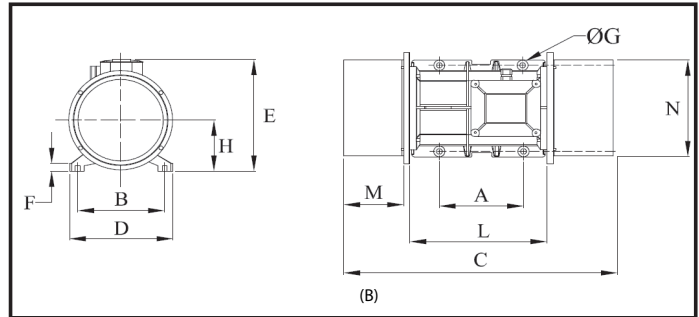

DRAWING - B

Vibration Force is adjusted simply by modifying the percentage of the unbalanced weight on the rotor shaft, desired force can be set by loosening the bolt of the outer eccentric weight on both sides and realigning the adjustable weight.

1. Adjustable Eccentric Weights - TYPE - A



2. Adjustable Eccentric Weights - TYPE - B

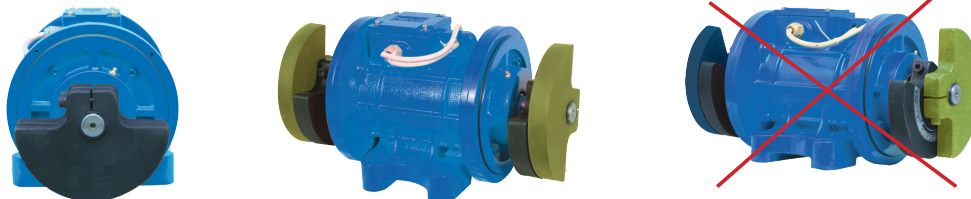

3. Tips to correctly Adjust the Eccentric Weights

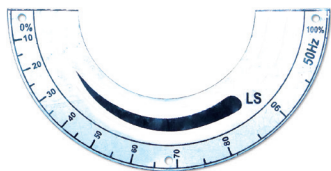

Rotate the eccentric weights following the design on the plate. From the thicker tip towards the thin trip

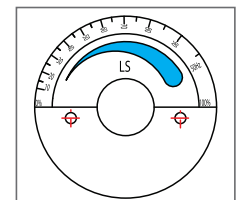

The fissure (slit) in eccentric weight should be treated as the base line for degree of adjustment

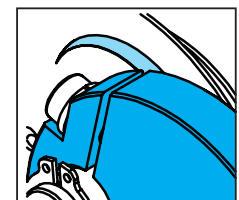

Note : Adjustment should be made on both sides and also the setting percentage should be same on both sides.

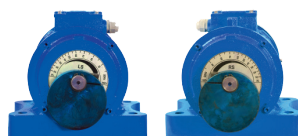

Rotate the Eccentric weights in the opposite direction to the cable gland

Vibrator Motor Position Selection For Hopper / Silos

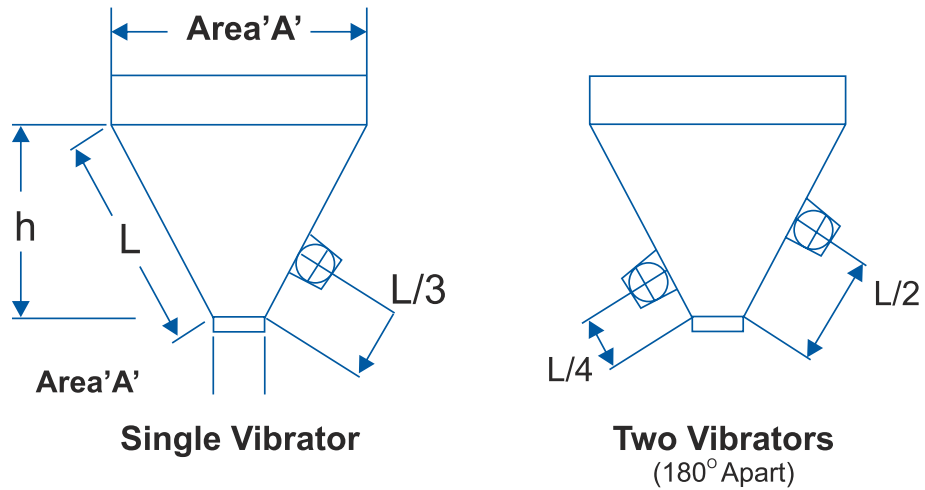

- Do not attach the motor directly to the hopper. Instead, weld a base plate to the hopper and bolt the motor to the base plate.
- Make sure the motor's protective circuits, including the ground wire are completely installed and operational.



SAFETY NOTES

The Vibrator motor shall be started only, if mounted for the defined use with the corresponding machine and all protection devices.

Attention: In case of handling or work with the vibrator motor the centrifugal weights of the vibrator motor may rotate unexpectedly.

Risk of injury

Overall protection of persons is insured only if the vibrator motors are closed completely.

The motor is not allowed to be used without protective cover of the centrifugal weights. The electrical connection of the vibrator

motor must be protected appropriately.

A damage insulation of the connection cable and missing covering of the terminal box may result in danger to life due to electrical shock. Eliminate such defects immediately.

Carryout any maintenance or setting work on the vibrator motor only with the motor at standstill.

Prior to the beginning of such work make sure that it is not possible to switch on the vibrator motor by error or unauthorized person.

Warning :

- Do not grease new motors before installation.
- Our Vibrator Motors with roller bearings leave the factory filled with right quantity of grease while those with rubber sealed ball bearing do not need any lubrication

Factory Address:

Pashamailaram Plot No. 11 & 12, Phase IV, APIIC, IDA. Pashamailaram 502 307, Patancheru Mandal, Medak Dist (TS) Tel : 08455 - 224501. Email: epdgeneral@jkenner.com



JK Fenner

Corporate Office:

Khivraj Complex II, V Floor,
480, Anna Salai, Nandanam, Chennai-600 035.
Tel: 4399 4666
E-mail : ptd_mhq@jkenner.com
Web: www.jkennerindia.com

Registered Office:

3, Madurai - Melakkal Road,
Kochadai, Madurai - 625 016.
Tel : 0452-4283800 Fax : 0452 -2383822.



BRANCHES:

- **Ahmedabad:** 602, Wall Street Annx., Near Gujarat College Railway Crossing, Ellis Bridge, Ahmedabad - 380006. Tel: 079-26408573 / 26408572.
- **Bangalore:** 20, New Timber Yard Layout, Mysore Road, Bangalore - 560 026. Tel: 080-26756333, Fax: 080-26741001.
- **Indore:** 58, New Dewas Road, Vallabh Nagar, Above SBI Branch, Malwa Mill Square, Indore - 452 003. Tel: 0731 4205048 / 4285048, 9981507191.
- **Jaipur:** 511, Neelkanth Tower, Bhawani Singh Road, Opposite Sahkar Bhawan, C Scheme, Jaipur - 302001 Tel : 141-2211075, 9799394727, 9950556644
- **Kanpur:** 123/45, Gadarian Purwa, Gold Spot Road, Kanpur - 208012 Tel: 0512-2235727, 97939 9997, Fax: 0512-2235727.
- **Kochi:** 32/563 A , J.K.Building, Pallissery Road, Palarivattom, Cochin - 682025. Tel: 0484-6003888, 98950 71066.
- **Kolkata:** DN 10, Merlin Matrix, Unit No 605, 6th Floor, Sector V, Salt Lake City, Kolkata - 700 091. Tel: 033-66168861.
- **Ludhiana:** B-XVII/2820/48, Opp to Adam Park, Jammu Colony, Link Road, Ludhiana - 141 003. Tel : 0161-2410214. Fax: 0161-2443791.
- **Madurai:** 117/6E, Madurai - Usilampatti Road, Meenakshipuram, Madurai - 625 016. Tel : 0452-2383920, Fax: 0452-2383921.
- **Navi Mumbai:** 105, Gauri Complex, Sector-11, CBD-Belapur, Navi Mumbai-400 614. Tel : 022-27560985, 022-27580236, Fax : 022-27563330.
- **New Delhi:** 2nd Floor, Delite Theatre Building, Asaf Ali Road, New Delhi - 110002. Tel : 011-23243113, 23243153, 23243154, Fax: 011-23243114.
- **Hyderabad:** Plot No. 35, TIE (Technocrat Industrial Estate), Behind Andhra Bank, Balanagar, Hyderabad 500 037. Tel: 040-23071126-39.